

Project:		Catalog #:		Type:	
----------	--	------------	--	-------	--

Prepared by:		Notes:		Date:	
--------------	--	--------	--	-------	--

## HBCNP Series

LED Round UFO High Bay Fixture  
CCT&Wattage Selectable • 5-yr Warranty



### KEY FEATURES

- Compact low-profile design allows light source to remain closer to the mounting plane
- EZCCT field-selectable CCT - 4000K & 5000K @ >90 CRI
- EZWATT field-selectable wattage - 150W, 120W, & 90W
- Standard Universal input voltage range: 120-277Vac
- Convenient twist-in plug-n-play occupancy sensor option available
- Suitable for wet location installations, rated IP65
- 0-10v dimmable
- NSF listed for ANSI 2 - Food Equipment Use



### Highlights



Toggle wattage and CCT with protected switches behind liquidtight twist-out cover

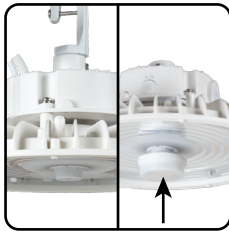

Easily add occupancy controls with front-accessible twist-in sensor



Two optional reflectors available, aluminum solid reflector and translucent polycarbonate reflector



Front diffusion lens available for both styles of reflector options above to further diffuse light output if desired



Mounting hook allows for easy 1 for 1 fixture replacement over existing fixtures, and narrow profile keeps light output close to ceiling height

### Load Information

Input Voltage	120-277Vac
Power Factor	0.90
THD	<20%
Low Temp Start	-40°C (-40°F)
Max Temp	50°C (122°F)
Unit Weight	4.6 lbs

### Dimensions

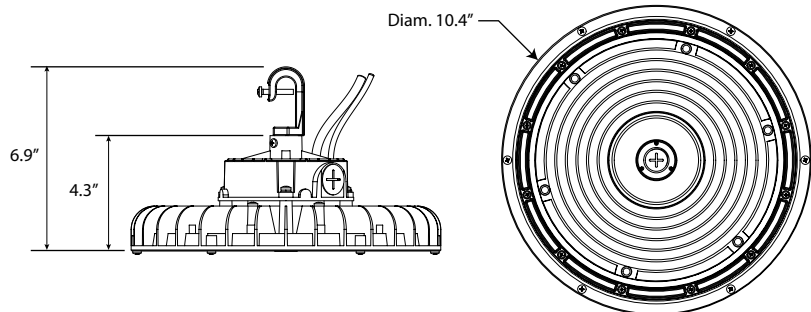

### Shipping Information

#### Packaged Item Information

Item	Weight	Box Qty.
HBCNP225E-84050-DS	5.25 lbs	1 per







#### Lumen Maintenance

Ambient Temp	TM-21 Lumen Maint. (50,000 hours)	Theoretical L70 (hours)
25°C	>70%	50,000

**Specifications**

Catalog Logic	Order #	Lumens	Wattage	LPW	Color Temp	CRI	Voltage	Dimming	DLC	Pallet Qty
HBCNP225E-84050-DS	80140	22,500, 18,000, 13,500 LM select	150W, 120W, 90W select	150	5000K, 4000K select	>80	120-277 Vac	0-10v	DLC 5.1P	TBA

**Accessories**

Item	Description	Reference
E1MS-SMW-LVP	Twist-in, plug-n-play occupancy sensor, installed after removing the front cover plug	
(TBA)	Twist-in, plug-n-play occupancy sensor, installed after removing the front cover plug, built-in Bluetooth connectivity to allow further customization using app. Allows for scheduling and grouping.	
HD05R	Wirelessly configure occupancy settings from the ground level, setting bi-level and tri-level output and timing controls (settings applied only to a single fixture)	
E2HBA-R	Further expand lateral diffusion and reduce lateral glare with this polycarbonate translucent reflector	
E1HBACC-ALREF	Control lateral glare with a 16" solid aluminum drop reflector	
E3HBC-TRING	Adapter ring required for installing polycarbonate or aluminum reflectors above	
E3HBC-LENS	Optional snap-on front diffuser lens for polycarbonate or aluminum reflector options above	



**ENERGETIC**  
L I G H T I N G

## HBCNP Series

LED Round UFO Highbay Fixture  
50,000 System Lifetime • 5-yr Warranty

### NOTES:



**ENERGETIC**  
L I G H T I N G

## HBCNP Series

LED Round UFO Highbay Fixture  
50,000 System Lifetime • 5-yr Warranty

### NOTES: