



ENERGETIC
LIGHTING

Project:		Catalog #:		Type:	
----------	--	------------	--	-------	--

Prepared by:		Notes:		Date:	
--------------	--	--------	--	-------	--

E5DL

LED Commercial Downlight
Selectable CCT
5", 7", 9", & 11" options •5-yr Warranty



KEY FEATURES

- E5CCT field-selectable CCT for all models with - 2700K, 3000K, 3500K, 4000K & 5000K @ >90 CRI
- 5", 7", 9", and 11" profiles available for design flexibility
- Ultra-thin profile at only 0.56 inch
- Install as surface-mounted over jbox or as recessed can retrofit where the 5-inch profile can fit over a 4" diameter can, and all other larger profiles can fit over 5"&6" diameter cans
- Optional decorative trim rings in black, brushed nickel, or bronze finish
- Optional emergency battery backup attachment available on the 7-inch model



Highlights



CCT color-selection switch located on back, choose among 2700K, 3000K, 3500K, 4000K, or 5000K

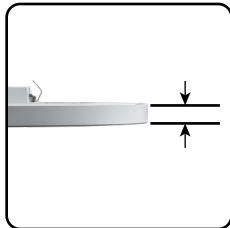

Ultra thin profile, measuring just a little over an inch



Optional emergency battery backup module

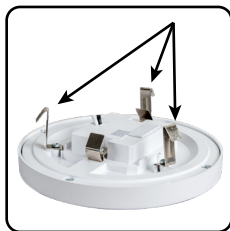

5-inch profile compatible with 4-inch recessed cans or direct J-box mounting

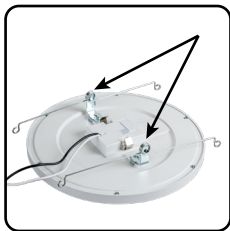

7, 9, & 11-inch profiles compatible with 5&6-inch recessed cans or direct J-box mounting



Installation in either a junction box or retrofit into a recessed can using the provided E26 adapter

Load Information

Input Voltage	120Vac	
Power Factor	0.90	
THD	<20%	
Low Temp Start	-25°C (-13°F)	
Max Temp	40°C (104°F)	
Unit Weight	5" profile	0.5 LBS
	7" profile	0.8 LBS
	9" profile	1.0 LBS
	11" profile	1.6 LBS

Shipping Information

Item	Weight	Box Qty.	Case Qty.
5" profile	0.8 LBS	1 per	12 per
7" profile	1.2 LBS	1 per	12 per
9" profile	1.7 LBS	1 per	12 per
11" profile	2.2 LBS	1 per	12 per

Dimensions

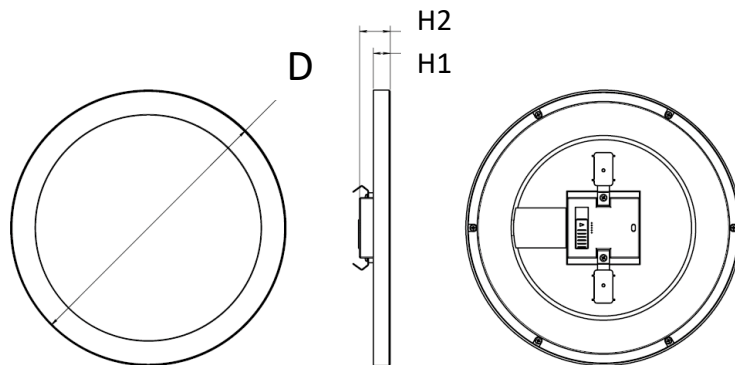

Size	D	H1	H2
5 inch	5.1"	0.6"	1.1"
7 inch	7.5"	0.6"	1.1"
9 inch	9.0"	0.6"	1.1"
11 inch	11.0"	0.6"	1.1"

STOCK ORDERING INFORMATION

5" Profile

Catalog Logic	Order #	Lumens	Wattage	LPW	Color Temp	CRI	Voltage	Dimming	Energy Star	Pallet Qty
E5DL5-92750	50110	700 LM	10 W	70	2700K, 3000K, 3500K, 4000K, 5000K select	90	120 Vac	Triac	Pending	TBA

7" Profile

Catalog Logic	Order #	Lumens	Wattage	LPW	Color Temp	CRI	Voltage	Dimming	Energy Star	Pallet Qty
E5DL7-92750	50111	900 LM	12 W	72	2700K, 3000K, 3500K, 4000K, 5000K select	90	120 Vac	Triac	Pending	TBA













9" Profile

Catalog Logic	Order #	Lumens	Wattage	LPW	Color Temp	CRI	Voltage	Dimming	Energy Star	Pallet Qty
E5DL9-92750	50112	1300 LM	18 W	72	2700K, 3000K, 3500K, 4000K, 5000K select	90	120 Vac	Triac	Pending	TBA

11" Profile

Catalog Logic	Order #	Lumens	Wattage	LPW	Color Temp	CRI	Voltage	Dimming	Energy Star	Pallet Qty
E5DL11-92750	50113	1800 LM	26 W	70	2700K, 3000K, 3500K, 4000K, 5000K select	90	120 Vac	Triac	Pending	TBA

Optional Accessories

Catalog Logic	Order #	Description	Reference
E5DL7-92750E	50114	7" EM Kits 120V 5-8W 5CCT Triac T20	
E5DL5-TRM-BK	50115	Trim of 5" slim downlight-Black	
E5DL5-TRM-BN	50116	Trim of 5" slim downlight-Brush Nickel	
E5DL5-TRM-BZ	50117	Trim of 5" slim downlight-Bronze	
E5DL7-TRM-BK	50118	Trim of 7" slim downlight-Black	
E5DL7-TRM-BN	50119	Trim of 7" slim downlight-Brush Nickel	
E5DL7-TRM-BZ	50120	Trim of 7" slim downlight-Bronze	
E5DL9-TRM-BK	50121	Trim of 9" slim downlight-Black	
E5DL9-TRM-BN	50122	Trim of 9" slim downlight-Brush Nickel	
E5DL9-TRM-BZ	50123	Trim of 9" slim downlight-Bronze	
E5DL11-TRM-BK	50124	Trim of 11" slim downlight-Black	
E5DL11-TRM-BN	50125	Trim of 11" slim downlight-Brush Nickel	
E5DL11-TRM-BZ	50126	Trim of 11" slim downlight-Bronze	



ENERGETIC
L I G H T I N G

E5DL

CCT-Select LED Commercial Downlight
50,000 System Lifetime • 5-yr Warranty

NOTES:

A large, empty rectangular box with a blue border, intended for user notes or specifications.