

LED Area Light

Please read and understand this entire manual before attempting to assemble, operate or install the product. Failure to do so could lead to electric shock, fire or other injuries that could be hazardous or even fatal.

Be sure the electricity to the wires you are working on is shut off. Either remove the fuse or turn off the circuit breaker.

Changes or modifications not expressly approved by the party responsible for compliance could void the user's authority to operate the equipment.

This product must be installed in accordance with local, state and national electrical codes.

Installation work shall be completed by a licensed installer that is familiar with the construction and operations of the product.

Components



Bracket A



Bracket B



Bracket C



Mounting Plate 1



Mounting Plate 2



Mounting Plate 3

Mounting instructions

Option 1

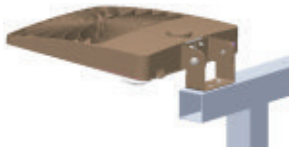

- *Take note of the position of any seals and gaskets, ensure that they are properly replaced if disturbed.
1. Feed the input cord through the center opening on Bracket C and affix Bracket C to fixture body using the 4 screws provided,
 2. Bracket angle can be adjusted by loosening the two locking screws and re-tightening once desired angle has been reached.
 3. Mount the bracket to the desired location with two screws through the two slots provided.

Option 2



1. Adjust Bracket A to the desired angle relative to the tenon arm by removing the two screws on side cover, loosen the inner locking bolt and re-tighten once desired angle is reached. Replace cover and gasket.
2. Fit the slip-fitter over tenon post and secure to tenon by tightening outer locking screws.

Option 3



1. Remove side cover plate from Bracket B by loosening the two screws.
2. Use Mounting Plate 3 as a template to drill through mounting surface, two for screws and center for power cord.
3. Secure the Bracket B to mounting surface using Mounting Plate 3 on the outside, and Mounting Plate 1 as an inner backing plate using 2 screws/nuts.
4. Replace side cover plate and gasket.

Option 4



1. Remove side cover plate from Bracket B by loosening the two screws.
2. Use Mounting Plate 2 as a template to drill through mounting surface, two for screws and center for power cord.
3. Secure Bracket B to mounting surface using Mounting Plate 2 on outside and Mounting Plate 1 as an inner backing plate using 2 screws/nuts.
4. Replace side cover plate and gasket.

NOTES:

- Make sure the luminaries are installed and fitted by a qualified electrician ensuring the installation complies to the current National Electrical Code and all local codes.
- Ensure all electrical connections are secure & that there are no loose strands.
- This is a Class I product and must be earthed.
- Install the fitting in a well-ventilated environment, keep away from corrosive/explosive materials, flammable gas or electric dust.
- Violent shaking or impact should be avoided when the fitting is working.
- Make sure that the fixings are adequate to support the weight of the fitting.
- Before installation or maintenance, turn off electric power and allow the fitting to be cool.

WIRING INSTRUCTION OF MAIN CABLE:

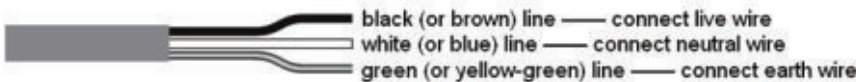

WARNING:

The product must be grounded and installed in accordance with the National Electrical Code and all local codes. Failure to do so may increase the RISH OF PERSONAL INJURY, PROPERTY DAMAGE, FIRE AND DEATH

E3SB-A1, E3SB-ARM, E3SB-SVL

E3SB series Shoebox Mounting Adapters

Three mounting options are available for the E3SB series shoebox fixtures. E3SB-A1 is an adjustable round slipfitter adapter that accommodates a variety of tenon angles. E3SB-ARM is a fixed-angle extension that mounts to either the flat face of a rectangular post, or round post. E3SB-SVL is a general purpose yoke adapter for flood light applications.

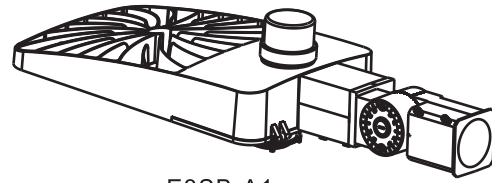

E3SB-A1
Round Slip-fitter

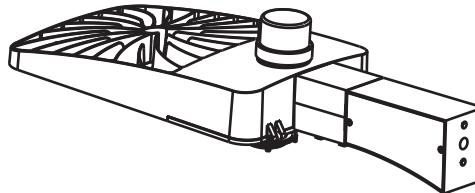

E3SB-Arm
Post Surface

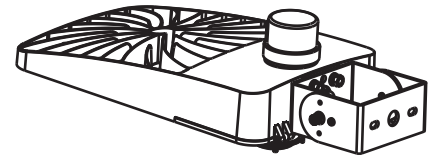

E3SB-SVL
Yoke adapter

Specifications

E3SB-A1

General Dimensions

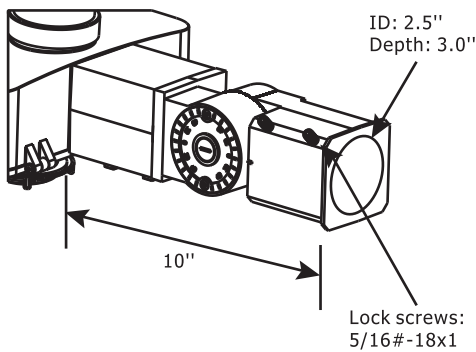

E3SB-ARM

General Dimensions

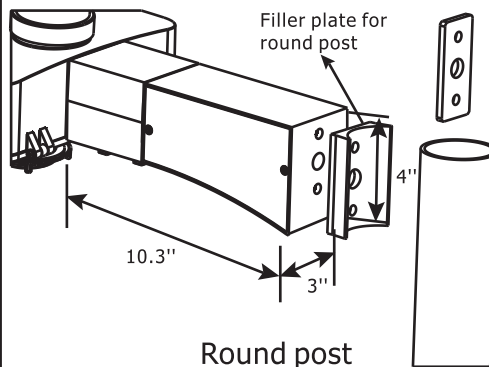
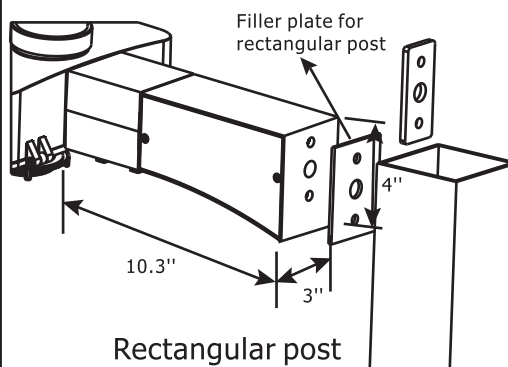

E3SB-SVL

General Dimensions

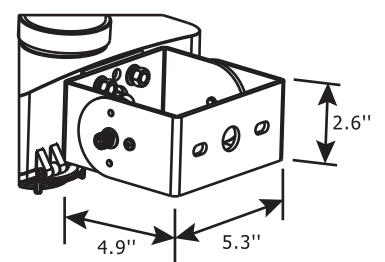

Adjustable swing angle range

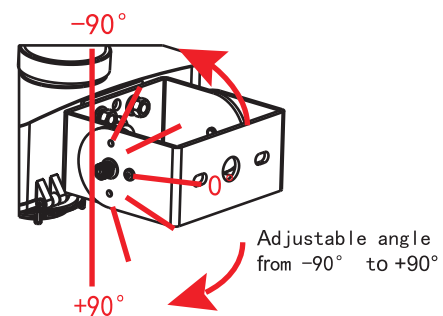

Bracket mounting pattern

Mounting screw slots
0.4" width x 1.1" length

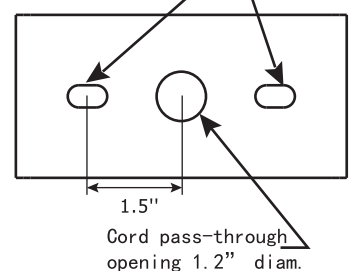

Adjustable swing angle range

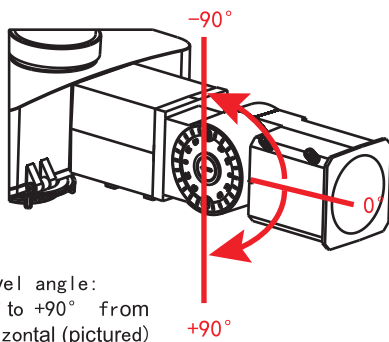

Bracket mounting pattern

