

E2DLS Series

LED LDisk Light
CCT-Selectable • 6-in profile



*Refer to the Stock Ordering Information Table below for qualified models

KEY FEATURES

- Convenient can-less downlight solution mounts directly into ceiling surface
- EZCCT field-selectable CCT - 2700K, 3000K, 3500K, 4000K & 5000K @ >90 & >80 CRI options
- Energy efficient input power of 12W
- Easy two-piece installation while maintaining a slim unobtrusive outer profile
- Suitable for wet location installations
- Dimmable down to 10% with standard 120Vac triac dimmer switches

Installation Overview

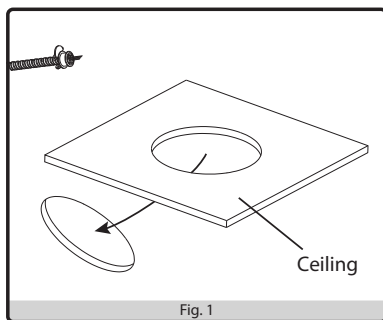

Installation can be made through cutting in a new ceiling or into an existing fixture with a through-hole (reflector needs to be removed first)

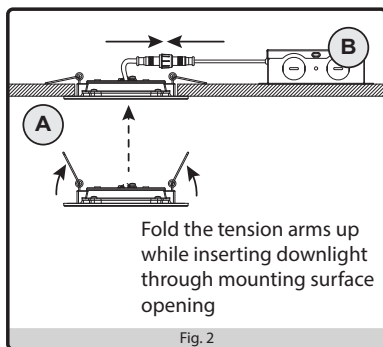

Mount the junction box (B) and make all electrical connections, pass the downlight (A) through ceiling surface and secure as shown.

Load Information

Input Voltage	120Vac
Power Factor	0.9
Low Temp Start	-20°C (-4°F)
Max Temp	40°C (104°F)
Unit Weight	TBA lbs

Dimensions

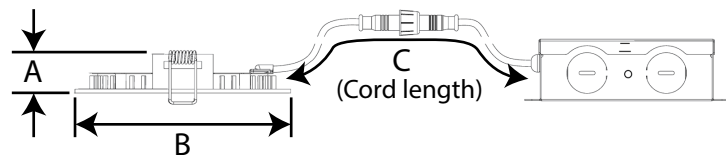

Description	Location	6 inch profile
Disk diameter	A	6.7"
Disk height	B	8.5"
Cord length	C	17.7"

Stock Ordering Information and Specifications

Catalog Logic	Order #	Lumens	Wattage	LPW	Color Temperature	CRI	Voltage	Dimming	Certifications	Pallet Qty
E2DLS6-92750-L90	65163	900 lm	12 W	75	2700K, 3000K, 3500K, 4000K, 5000K selectable	90	120Vac	Triac	ETL	TBA
E2DLS6-850-L105	65161	1050 lm	12 W	85	2700K, 3000K, 3500K, 4000K, 5000K selectable	80	120Vac	Triac	ETL	TBA
E2DLS6-82765	75015	1050 lm	12 W	85	2700K, 3000K, 4000K, 5000K, 6500K selectable	80	120Vac	Triac	ETL	TBA